



McGuire Manufacturing Co., Inc.

60 Grandview Court
 Cheshire, Connecticut 06410
 (203) 699-1801 Fax (203) 699-1813
 customerservice@mcguiremfg.com mcguiremfg.com

Part No.

201, 202, 204, 205

**NY Regulation
 Cast P-Trap**

PRODUCT SPECIFICATION

Job Name:

Submittal Number:

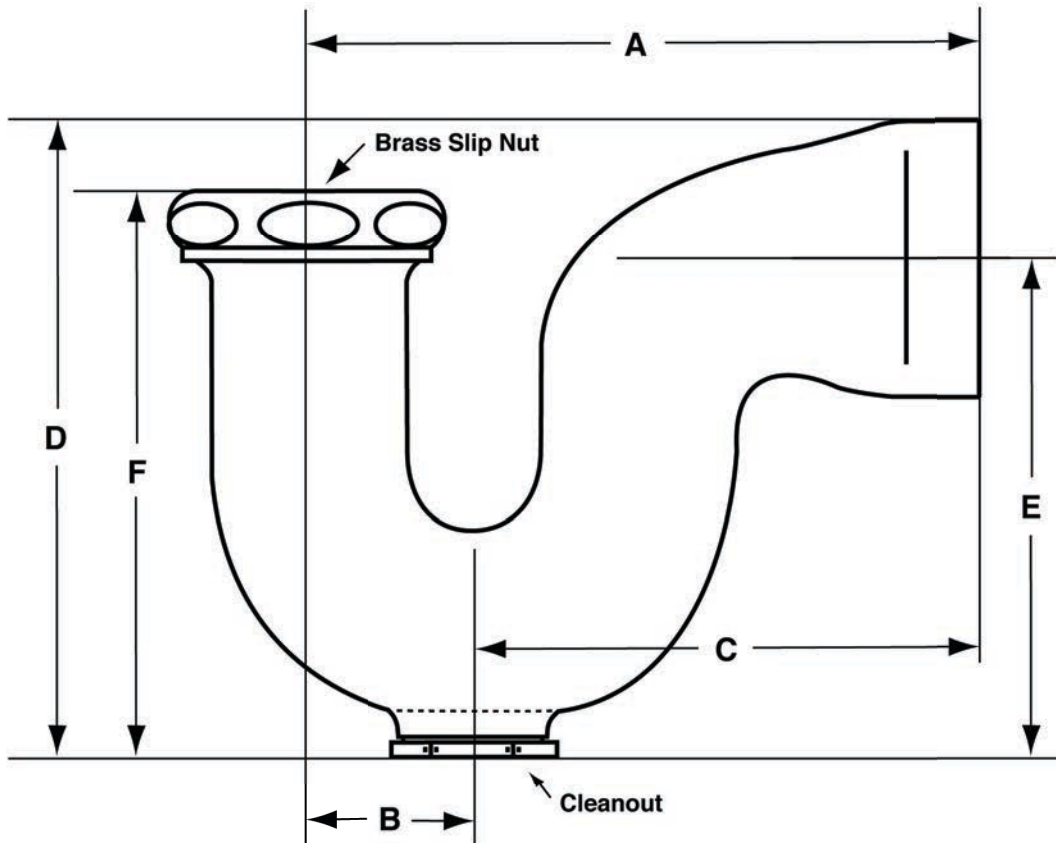

ROUGHING MEASUREMENTS

NO.	TRAP DIMENSIONS		A	B	C	D	E	F
	INLET	OUTLET						
201	1-1/4"	I.P.S 1-1/2"	4-3/4"	1-1/4"	3-1/4"	4-3/4"	4"	3-7/8"
202	1-1/2"	I.P.S 1-1/2"	4-3/4"	1-1/4"	3-1/4"	4-3/4"	4"	3-7/8"
204	1-1/2"	I.P.S 2"	5-5/16"	1-3/4"	3-9/16"	6-3/8"	5"	4-7/8"
205	2"	I.P.S 2"	5-5/16"	1-3/4"	3-9/16"	6-3/8"	5"	4-7/8"

**FED SPEC W.W.P. 541
 CAST BRASS P TRAP
 MINIMUM SEAL 2"**

See options and accessories section for details on product variations.

Specifications:

P-Trap shall be chrome plated cast brass with cleanout, female IPS outlet, and cast brass slip nut. With (shallow, deep, bell) (steel, brass) or (forged brass with set screw) flange. P-Trap shall be McGuire (201, 202, 204, 205).



WARNING:

This product can expose you to chemicals including lead, which is known to the State of California to cause cancer, and birth defects or other reproductive harm. For more information go to www.P65Warnings.ca.gov.



McGuire Manufacturing Co., Inc.

60 Grandview Court
 Cheshire, Connecticut 06410
 (203) 699-1801 Fax (203) 699-1813
 customerservice@mcguiremfg.com mcguiremfg.com

Part No.
8088, 8089, 8089CNC,
8090, 8090CNC, 1207, 1208

Cast P-Trap Ground Joint
Swivel With Or
Without Cleanout

PRODUCT SPECIFICATION

Job Name:

Submittal Number:

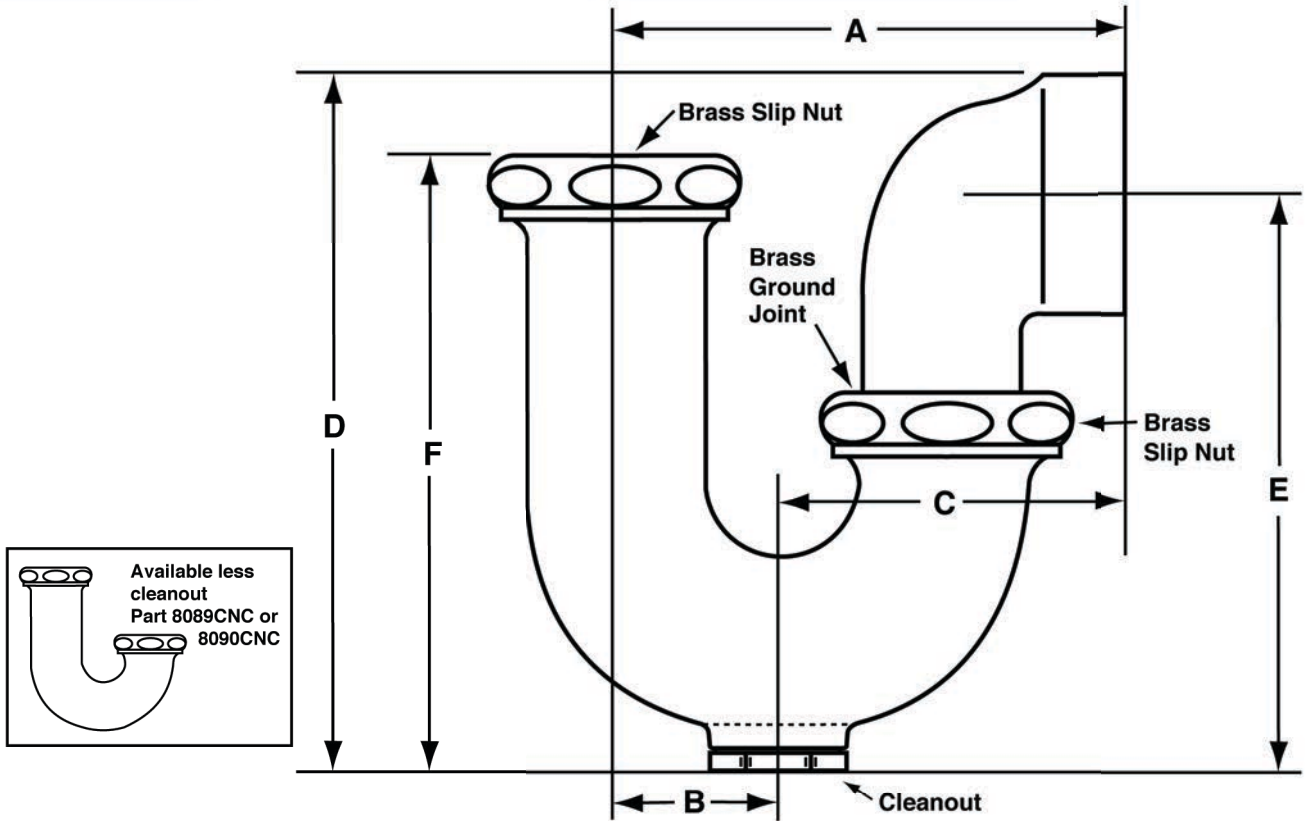

ROUGHING MEASUREMENTS

NO.	TRAP DIMENSIONS		A	B	C	D	E	F
	INLET	OUTLET						
8088	1-1/4" x 1-1/4"	IPS 1-1/4"	4-3/16"	1-1/4"	2-15/16"	5-1/2"	4-1/2"	5"
8089	1-1/2" x 1-1/2"	IPS 1-1/2"	4-1/4"	1-3/8"	2-7/8"	5-3/4"	4-5/8"	5"
8089CNC	1-1/2" x 1-1/2"	IPS 1-1/2"	4-1/4"	1-3/8"	2-7/8"	5-3/8"	4-1/4"	4-5/8"
8090	1-1/4" x 1-1/2"	IPS 1-1/2"	4-1/4"	1-3/8"	2-7/8"	5-3/4"	4-5/8"	5"
8090CNC	1-1/4" x 1-1/2"	IPS 1-1/2"	4-1/4"	1-3/8"	2-7/8"	5-3/8"	4-1/4"	4-5/8"
1207	1-1/2"	IPS 2"	5-3/8"	1-3/4"	3-5/8"	6-5/8"	5-1/4"	5-1/16"
1208	2"	IPS 2"	5-3/8"	1-3/4"	3-5/8"	6-5/8"	5-1/4"	5-1/16"

FED SPEC W.W.P. 541
CAST BRASS P-TRAP
MINIMUM SEAL 2"

See options and accessories section for details on product variations.

ASME A112.18.2/CSA B125.2



Specifications:

P-Trap shall be chrome plated cast brass body (with, without) cleanout, cast brass ground joint elbow and cast brass slip nut. No reducing washers. With (shallow, deep, bell) (steel, brass) or (forged brass with set screw) flange. P-Trap shall be McGuire (8088, 8089, 8090, 1207, 1208). Trap shall be certified by CSA or other recognized testing authority. P-Trap shall bear manufacturer and testing mark.



WARNING:

This product can expose you to chemicals including lead, which is known to the State of California to cause cancer, and birth defects or other reproductive harm. For more information go to www.P65Warnings.ca.gov.



McGuire Manufacturing Co., Inc.

60 Grandview Court
 Cheshire, Connecticut 06410
 (203) 699-1801 Fax (203) 699-1813
 customerservice@mcguiremfg.com mcguiremfg.com

PRODUCT SPECIFICATION

Part No.

8089 and 8090 Series

Boston Sweat P-Trap

Job Name:

Submittal Number:

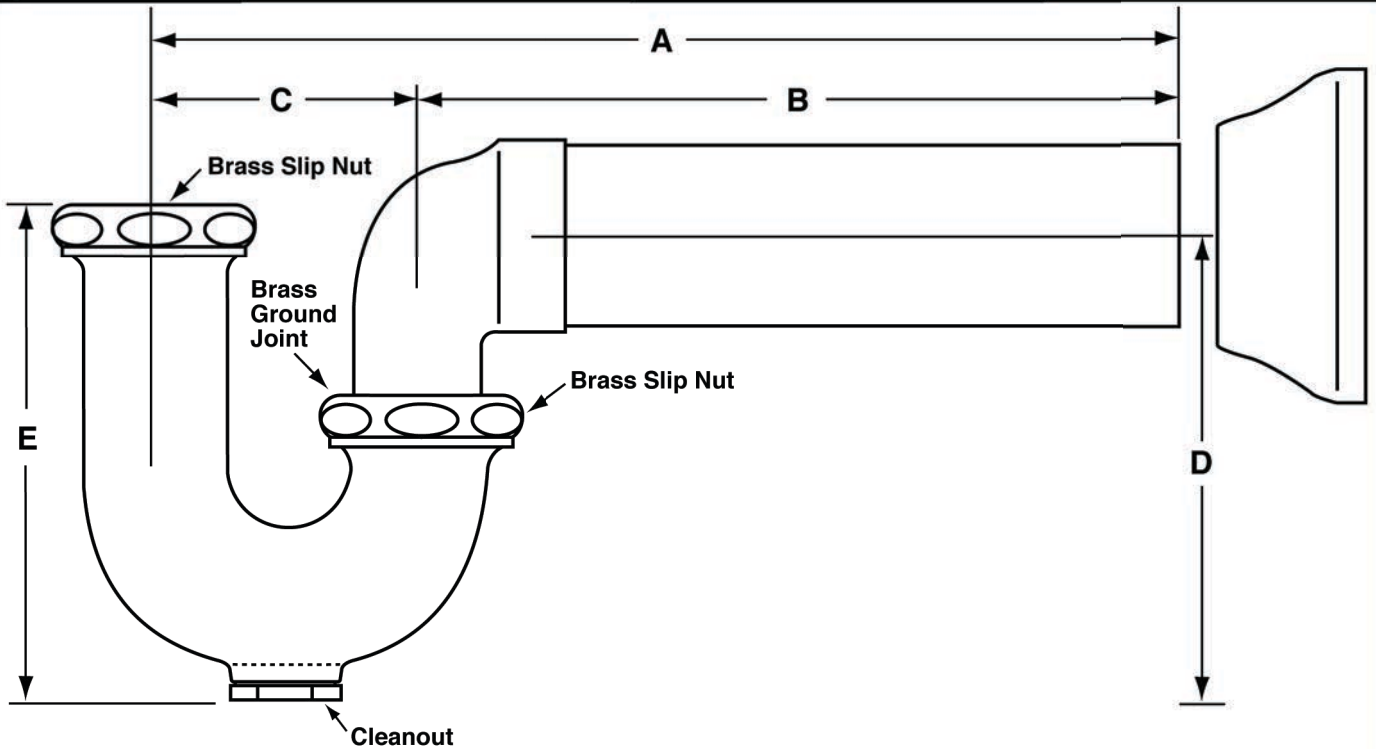

ROUGHING MEASUREMENTS

NO.	TRAP DIMENSIONS		A	B	C	D	E
	INLET	OUTLET					
8090CBOS4	1-1/4"	1-1/2" w/4" Sweat Extension	8"	5"	3"	4-1/2"	5"
8090CBOS6	1-1/4"	1-1/2" w/6" Sweat Extension	10"	7"	3"	4-1/2"	5"
8090CBOS8	1-1/4"	1-1/2" w/8" Sweat Extension	12"	9"	3"	4-1/2"	5"
8090CBOS12	1-1/4"	1-1/2" w/12" Sweat Extension	16"	13"	3"	4-1/2"	5"
8089CBOS4	1-1/2"	1-1/2" w/4" Sweat Extension	8"	5"	3"	4-1/2"	5"
8089CBOS6	1-1/2"	1-1/2" w/6" Sweat Extension	10"	7"	3"	4-1/2"	5"
8089CBOS8	1-1/2"	1-1/2" w/8" Sweat Extension	12"	9"	3"	4-1/2"	5"
8089CBOS12	1-1/2"	1-1/2" w/12" Sweat Extension	16"	13"	3"	4-1/2"	5"

Note: Minimum seal 2"

See options and accessories section for details on product variations.



ASME A112.18.2/CSA B125.2

Specifications:

P-Trap shall be chrome plated cast brass body with cleanout, 17 gauge seamless tubular sweat extension, cast brass ground joint elbow, and cast brass slip nuts. No reducing washers. With (shallow, deep, bell) (steel, brass) or (forged brass with set screw) flange.



WARNING:

This product can expose you to chemicals including lead, which is known to the State of California to cause cancer, and birth defects or other reproductive harm. For more information go to www.P65Warnings.ca.gov.



McGuire Manufacturing Co., Inc.

60 Grandview Court
 Cheshire, Connecticut 06410
 (203) 699-1801 Fax (203) 699-1813
 customerservice@mcguiremfg.com mcguiremfg.com

Part No.

8872CBECO, C8872CECO, 8904CBECO
 8912CBECO, C8912CECO,
 8912CNCBECO, 8912C18BECO

PRODUCT SPECIFICATION

Cast Body P-Trap With or Without Cleanout

Job Name:

Submittal Number:

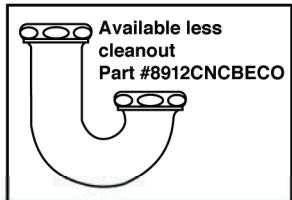
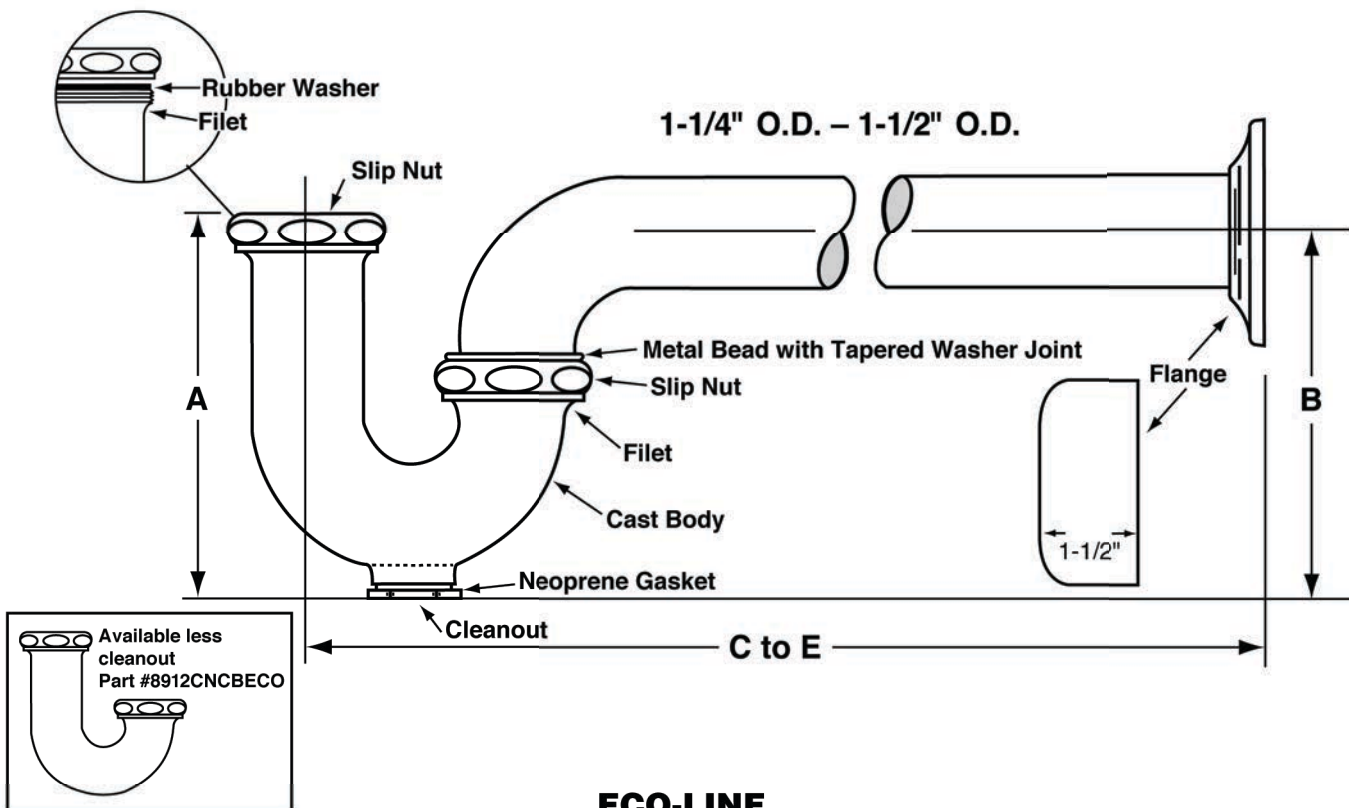

ECO-LINE

ROUGHING MEASUREMENTS

MODEL NO.	TRAP DIMENSIONS		A	B	C to E	FLANGE	SLIP NUT
	INLET	OUTLET					
8872CBECO	1-1/4"	1-1/4"	4-1/2"	4-1/2"	11"	Box	Brass
C8872CECO	1-1/4"	1-1/4"	4-1/2"	4-1/2"	10"	Shallow	Zinc
8904CBECO	1-1/2", 2"	2"	5"	6"	13-1/2"	Box	Brass
8912CBECO	1-1/2", 1-1/4"	1-1/2"	5"	5"	12"	Box	Brass
C8912CECO	1-1/2", 1-1/4"	1-1/2"	5"	5"	10-1/2"	Shallow	Zinc
8912CNCBECO	1-1/2", 1-1/4"	1-1/2"	4-3/4"	4-1/2"	12"	Box	Brass
8912C18BECO	1-1/2", 1-1/4"	1-1/2"	5"	5"	18"	Box	Brass

FED SPEC W.W.P. 541
 CAST BRASS P-TRAP
 MINIMUM SEAL 2"



ASME A112.18.2/CSA B125.2

Specifications:

Chrome plated P-Trap shall be cast brass body, with or without cleanout, with 17 gauge seamless tubular wall bend and flange.



WARNING:

This product can expose you to chemicals including lead, which is known to the State of California to cause cancer, and birth defects or other reproductive harm. For more information go to www.P65Warnings.ca.gov.



McGuire Manufacturing Co., Inc.

60 Grandview Court
 Cheshire, Connecticut 06410
 (203) 699-1801 Fax (203) 699-1813
 customerservice@mcguiremfg.com mcguiremfg.com

PRODUCT SPECIFICATION

Part No.

**B8872, B8902, B8902CNC,
 B8912, B8912CNC,
 C8872, C8902, C8912**

**Cast Body P-Trap
 With or Without Cleanout**

Job Name:

Submittal Number:

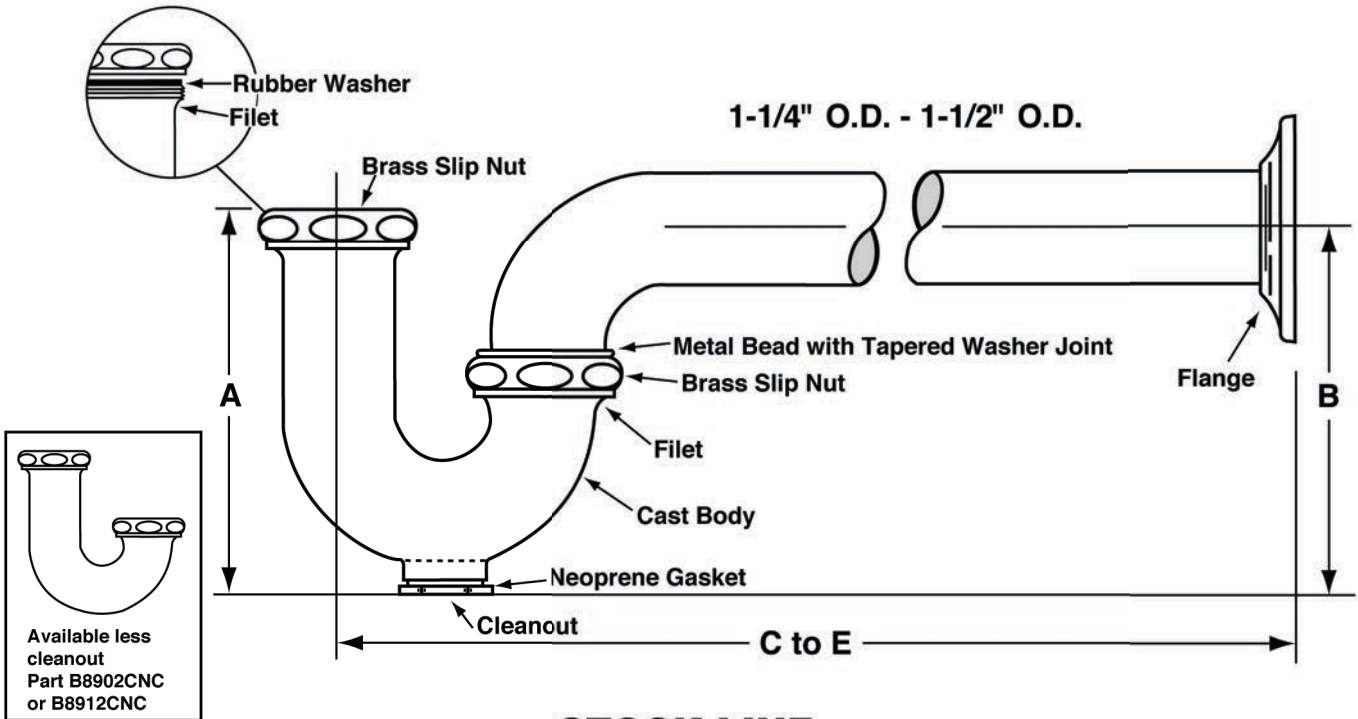

STOCK LINE

ROUGHING MEASUREMENTS					
NO.	TRAP DIMENSIONS		A	B	C to E
	INLET	OUTLET			
B8872	1-1/4"	1-1/4"	4-1/2"	4-1/2"	10-1/2"
C8872	1-1/4"	1-1/4"	4-1/2"	4-1/4"	10"
B8902	1-1/4"	1-1/2"	5"	5-1/2"	10-1/2"
B8902CNC	1-1/4"	1-1/2"	4-3/4"	4-1/2"	10-1/2"
C8902	1-1/4"	1-1/2"	5"	5-1/2"	10-1/2"
B8912	1-1/2"	1-1/2"	5"	4-1/2"	10-1/2"
B8912CNC	1-1/2"	1-1/2"	4-5/8"	4-1/8"	10-1/2"
C8912	1-1/2"	1-1/2"	5"	4-1/2"	10-1/2"

Note: Prefix "C" indicates die cast slip nuts.

**FED SPEC W.W.P. 541
 CAST BRASS P TRAP
 MINIMUM SEAL 2"**



See options and accessories section for details on product variations.

ASME A112.18.2/CSA B125.2

Specifications:

P-Trap shall be chrome plated cast brass body (with, without) cleanout, with 17 gauge seamless tubular wall bend, slip nuts. Reducing washers shall be used with reducing cast brass nut. With (shallow, deep, bell) (steel, brass) or (forged brass with set screw) flange. P-Trap shall bear manufacturer and testing mark.



WARNING:

This product can expose you to chemicals including lead, which is known to the State of California to cause cancer, and birth defects or other reproductive harm. For more information go to www.P65Warnings.ca.gov.



McGuire Manufacturing Co., Inc.

60 Grandview Court
 Cheshire, Connecticut 06410
 (203) 699-1801 Fax (203) 699-1813
 customerservice@mcguiremfg.com mcguiremfg.com

PRODUCT SPECIFICATION

Part No.

**MCT125 and
 MCT150 Series**

**Lite Commercial 17 GA
 Tubular P-Trap**

Job Name:

Submittal Number:

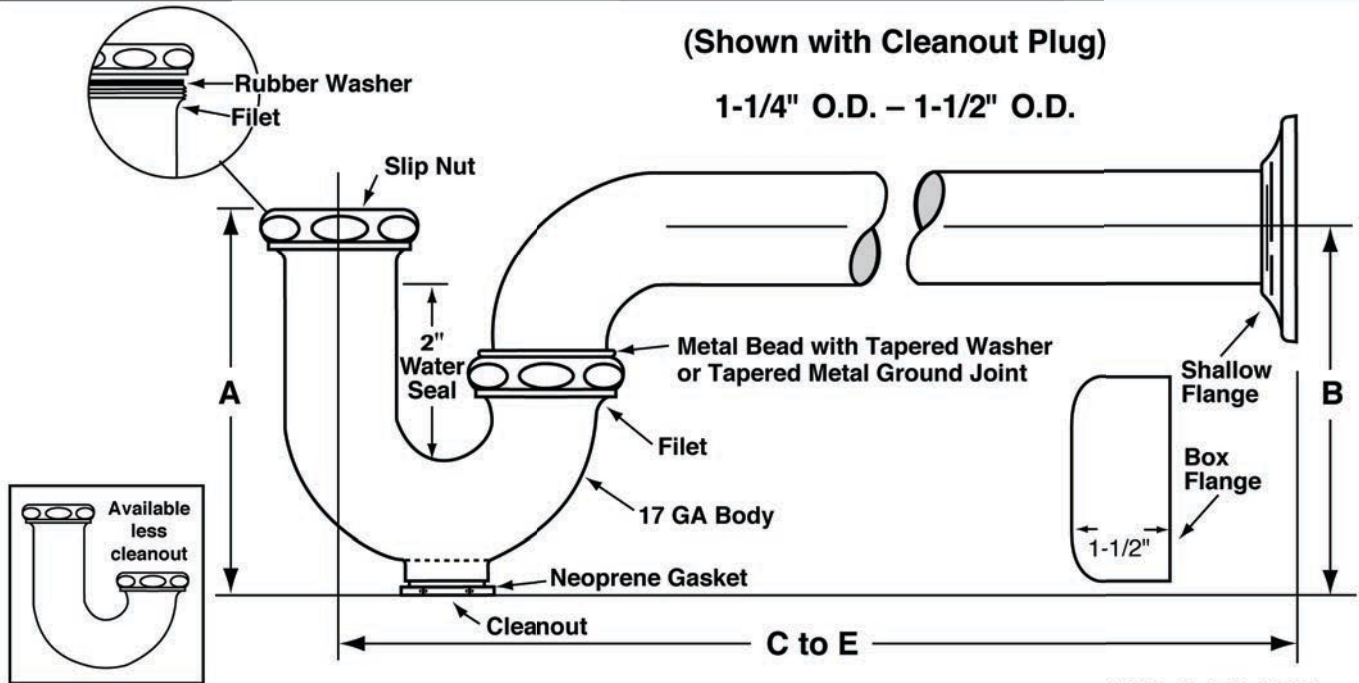

LITE COMMERCIAL ADJUSTABLE 17 GAUGE TUBULAR P-TRAPS

Roughing Measurements

Model No.	INLET	OUTLET	A	B	C to E	Flange	Slip Nut
MCT125085	1-1/4"	1-1/4"	5"	4-1/2"	11-1/2"	Shallow	Brass
MCT125085B	1-1/4"	1-1/4"	5-1/4"	4-1/2"	11-1/2"	Box	Brass
MCT125085NC	1-1/4"	1-1/4"	5"	5"	11-1/2"	Shallow	Brass
MCT125085NCB	1-1/4"	1-1/4"	5"	4-5/8"	11-1/2"	Box	Brass
MCT125075ZN	1-1/4"	1-1/4"	5-1/4"	4-3/4"	10-1/2"	Shallow	Zinc
MCT125075NCZN	1-1/4"	1-1/4"	5"	4-1/2"	10-1/2"	Shallow	Zinc
MCT150090B	1-1/2", 1-1/4"	1-1/2"	5-1/4"	5"	12"	Box	Brass
MCT150075ZN	1-1/2", 1-1/4"	1-1/2"	5-1/2"	5"	10-1/2"	Shallow	Zinc
MCT150075NCZN	1-1/2", 1-1/4"	1-1/2"	5"	4-3/4"	11"	Shallow	Zinc
MCT150090NCB	1-1/2", 1-1/4"	1-1/2"	5-1/4"	4-1/2"	12-1/4"	Box	Brass
MCT150090NCGJB	1-1/2", 1-1/4"	1-1/2"	5-1/4"	4-3/4"	12-1/4"	Box	Brass
MCT150090NCGJ	1-1/2", 1-1/4"	1-1/2"	5-1/4"	5"	12-1/4"	Shallow	Brass
MCT150150B	1-1/2", 1-1/4"	1-1/2"	5-1/4"	5"	18"	Box	Brass

Suffix Designations

NC = No Cleanout Plug

GJ = Ground Joint Wall Bend



ASME A112.18.2/CSA B125.2

Specifications:

P-Trap shall be 17 gauge seamless chrome plated tubular brass with wall bend and flange.

WARNING:

This product can expose you to chemicals including lead, which is known to the State of California to cause cancer, and birth defects or other reproductive harm. For more information go to www.P65Warnings.ca.gov.



McGuire Manufacturing Co., Inc.

60 Grandview Court
 Cheshire, Connecticut 06410
 (203) 699-1801 Fax (203) 699-1813
 customerservice@mcguiremfg.com mcguiremfg.com

PRODUCT SPECIFICATION

Part No.

MCT150UTL17B

**17GA P-Trap
 Adjustable Milwaukee
 Style, N.Y. Utility Style**

Job Name:

Submittal Number:

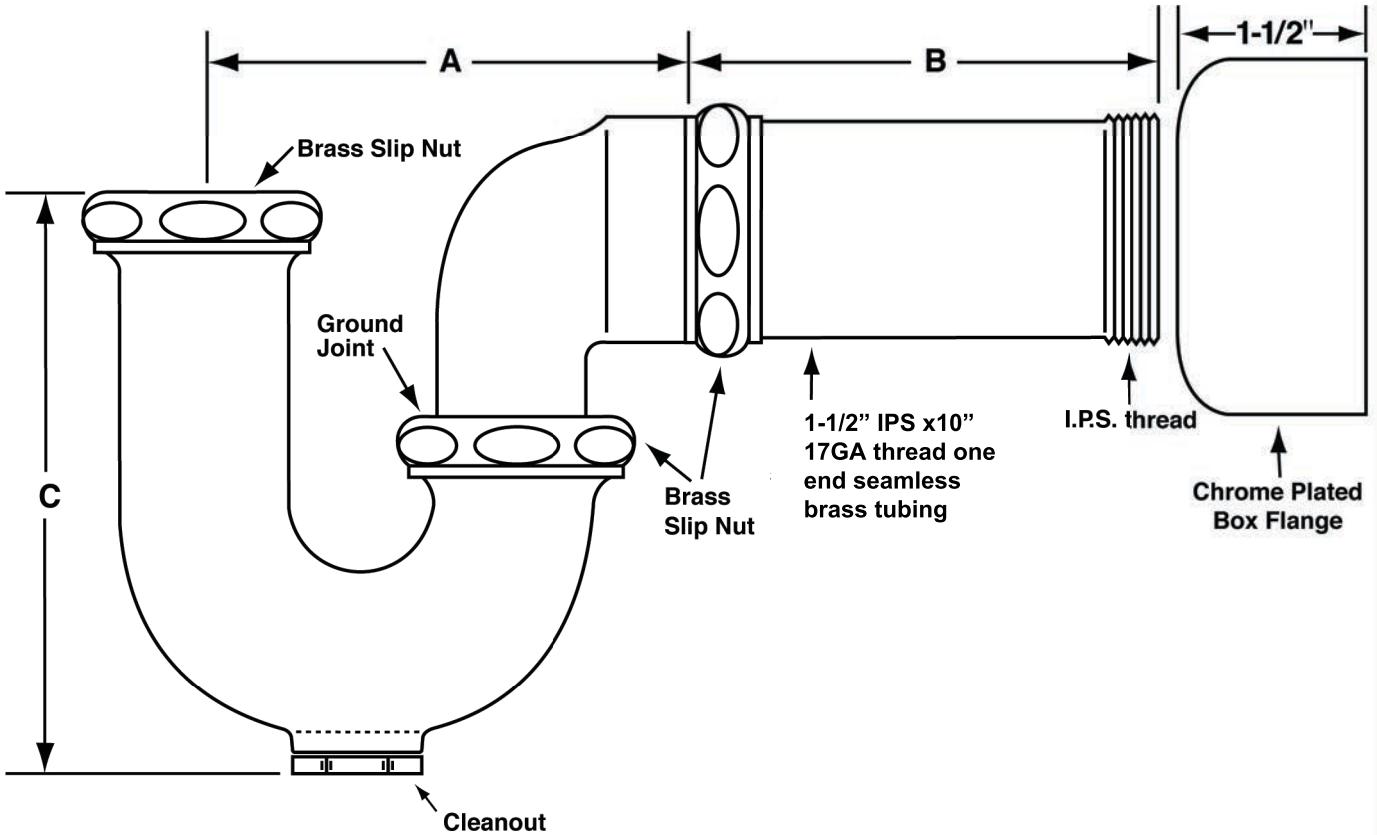

ROUGHING MEASUREMENTS

NO.	TRAP DIMENSIONS		A	B	C
	INLET	OUTLET			
MCT150UTL17B	1-1/4" x 1-1/2", 1-1/2"	1-1/2" x 10" Slip x I.P.S. 17 G.A. T.O.E. Brass Tube	4-1/4"	10"	5"



ASME A112.18.2/CSA B125.2

Specifications:

P-Trap shall be 17 GA seamless tubular chrome plated brass with 17 GA utility arm and flange.



WARNING:

This product can expose you to chemicals including lead, which is known to the State of California to cause cancer, and birth defects or other reproductive harm. For more information go to www.P65Warnings.ca.gov.



McGuire Manufacturing Co., Inc.

60 Grandview Court
Cheshire, Connecticut 06410
(203) 699-1801 Fax (203) 699-1813
customerservice@mcguiremfg.com mcguiremfg.com

PRODUCT SPECIFICATION

Part No.

**Options for
P-Traps**

Job Name:

Submittal Number:

CAST BODY P-TRAP OPTIONS

WALL BEND OPTIONS –

Add suffix to part number.

- 15** – 15" C to E (1-1/4" and 1-1/2" only)
- 18** – 18" C to E (1-1/4" and 1-1/2" only)
- GJ** – Ground joint wallbend
Custom sizes available.

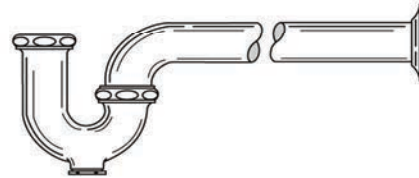

FLANGE OPTIONS–

Add suffix to part number.

- F** – Forged Brass, set screw, chrome plated
- DF** – Deep Flange, (bell type) chrome plated brass
- SDF** – Deep Flange, (bell type) chrome plated steel
- B** – Box Flange, chrome plated wrought steel
- BF** – Box Flange, chrome plated brass

STANDARD FINISH OPTIONS–

Add suffix to part number.

- C** – Polished Chrome
- S** – Satin Chrome
Custom finishes available.

Options available for McGuire “Classic” Professional Line only.



McGuire Manufacturing Co., Inc.

60 Grandview Court
 Cheshire, Connecticut 06410
 (203) 699-1801 Fax (203) 699-1813
 customerservice@mcguiremfg.com mcguiremfg.com

PRODUCT SPECIFICATION

Part No.

8872C, 8902C, 8902CNC, 8912C,
 8912CNC, 8903C, 8904C

Cast Body P-Trap With or Without Cleanout

Job Name:

Submittal Number:

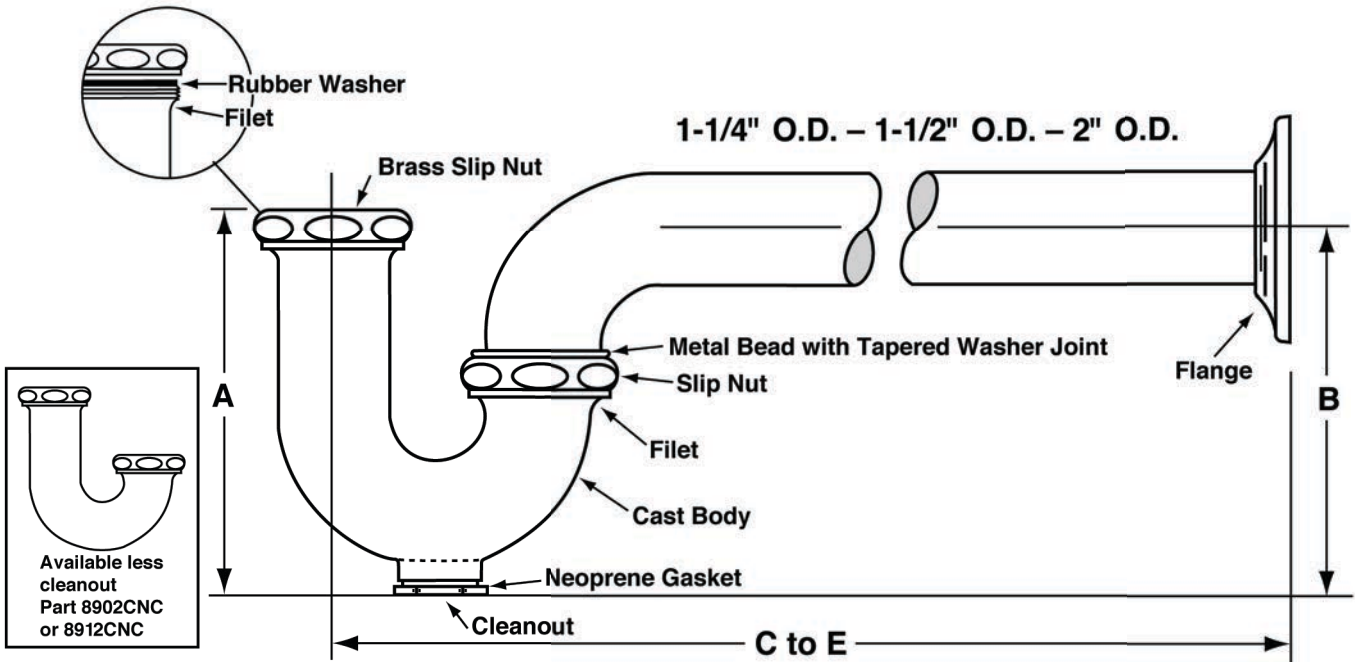

PROFESSIONAL LINE

ROUGHING MEASUREMENTS

NO.	TRAP DIMENSIONS		A	B	C to E
	INLET	OUTLET			
8872C	1-1/4"	1-1/4"	4-1/2"	4-1/4"	11-1/2"
8902C	1-1/4"	1-1/2"	5"	5-1/2"	11-1/2"
8902CNC	1-1/4"	1-1/2"	4-5/8"	4-3/4"	11-1/2"
8912C	1-1/2"	1-1/2"	5"	5-1/2"	11-1/2"
8912CNC	1-1/2"	1-1/2"	4-5/8"	4-1/8"	11-1/2"
8903C	1-1/2"	2"	5"	6"	13-3/4"
8904C	2"	2"	5"	6"	13-3/4"

FED SPEC W.W.P. 541
CAST BRASS P TRAP
MINIMUM SEAL 2"

See options and accessories section for details on product variations.

ASME A112.18.2/CSA B125-2



Specifications:

P-Trap shall be chrome plated cast brass body (with, without) cleanout, with 17 gauge seamless tubular wall bend, cast brass slip nuts. Reducing washers shall be used with reducing cast brass nut. With (shallow, deep, bell) (steel, brass) or (forged brass with set screw) flange.

P-Trap shall be McGuire "Classic" Professional Line

Trap shall be certified by CSA or other recognized testing authority. Trap shall bear manufacturer and testing marks.



WARNING:

This product can expose you to chemicals including lead, which is known to the State of California to cause cancer, and birth defects or other reproductive harm. For more information go to www.P65Warnings.ca.gov.



McGuire Manufacturing Co., Inc.

60 Grandview Court
 Cheshire, Connecticut 06410
 (203) 699-1801 Fax (203) 699-1813
 customerservice@mcguiremfg.com mcguiremfg.com

PRODUCT SPECIFICATION

Part No.

**V8089C, V8089CNC,
 V8090C, V8090CNC**

**Vandal Resistant Ground
 Joint Swivel P-Trap
 With or Without Cleanout**

Job Name:

Submittal Number:

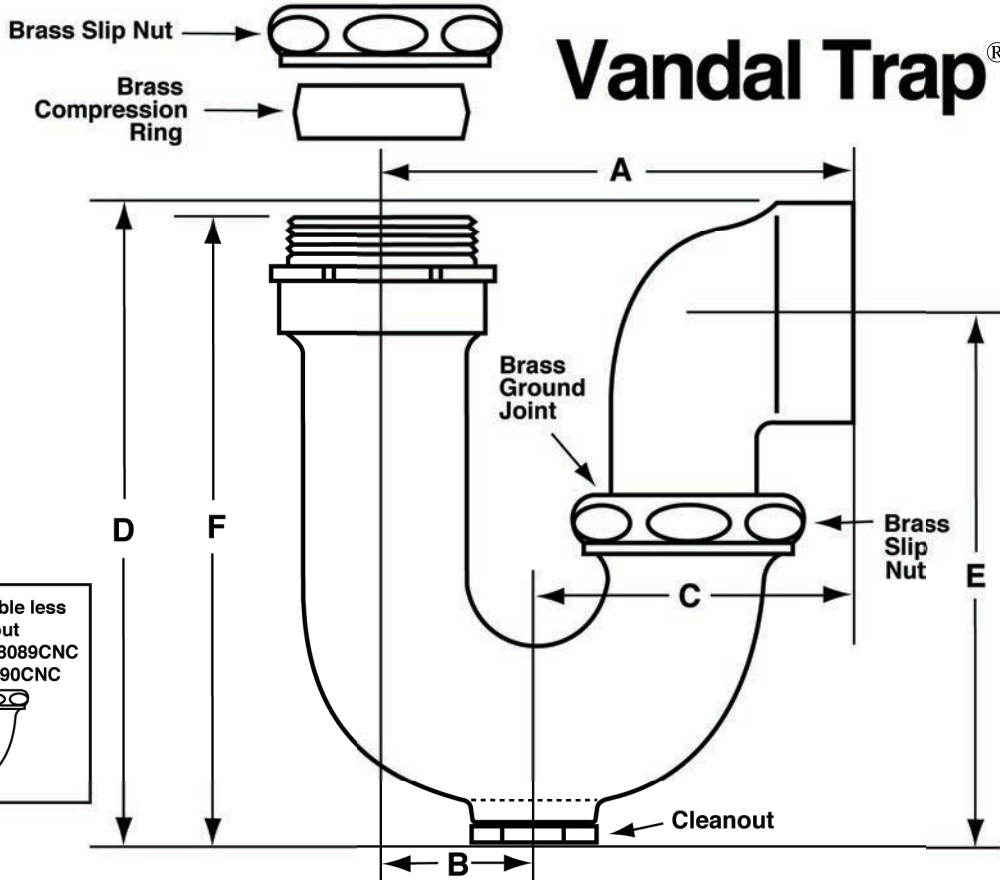

ROUGHING MEASUREMENTS

NO.	TRAP DIMENSIONS		A	B	C	D	E	F
	INLET	OUTLET						
V8089C	1-1/2" x 1-1/2"	S.P.S. 1-1/2"	4-1/4"	1-3/8"	2-7/8"	5-3/4"	4-5/8"	5-1/2"
V8089CNC	1-1/2" x 1-1/2"	S.P.S. 1-1/2"	4-1/4"	1-3/8"	2-7/8"	5-3/8"	4-1/4"	5-1/8"
V8090C	1-1/4" x 1-1/2"	S.P.S. 1-1/2"	4-1/4"	1-3/8"	2-7/8"	5-3/4"	4-5/8"	5-1/2"
V8090CNC	1-1/4" x 1-1/2"	S.P.S. 1-1/2"	4-1/4"	1-3/8"	2-7/8"	5-3/8"	4-1/4"	5-1/8"

**FED SPEC W.W.P. 541
 CAST BRASS P TRAP
 MINIMUM SEAL 2"**

See options and accessories section for details on product variations.



ASME A112.18.2/CSA B125.2

Specifications:

Cast brass chrome plated adjustable ground joint swivel P-Trap, vandal resistant, with cleanout. Furnished with cast brass J-Bend with or without cleanout, cast brass slip nuts, heavy brass vandal inlet and cast brass elbow. Trap shall be certified by CSA or other recognized testing authority and shall bear manufacturer and testing mark.



WARNING:

This product can expose you to chemicals including lead, which is known to the State of California to cause cancer, and birth defects or other reproductive harm. For more information go to www.P65Warnings.ca.gov.



McGuire Manufacturing Co., Inc.

60 Grandview Court
 Cheshire, Connecticut 06410
 (203) 699-1801 Fax (203) 699-1813
 customerservice@mcguiremfg.com mcguiremfg.com

Part No.

**V8902C, V8902CNC,
 V8912C, V8912CNC**

**Vandal Resistant P-Trap
 With or Without Cleanout**

PRODUCT SPECIFICATION

Job Name:

Submittal Number:

Vandal Trap®

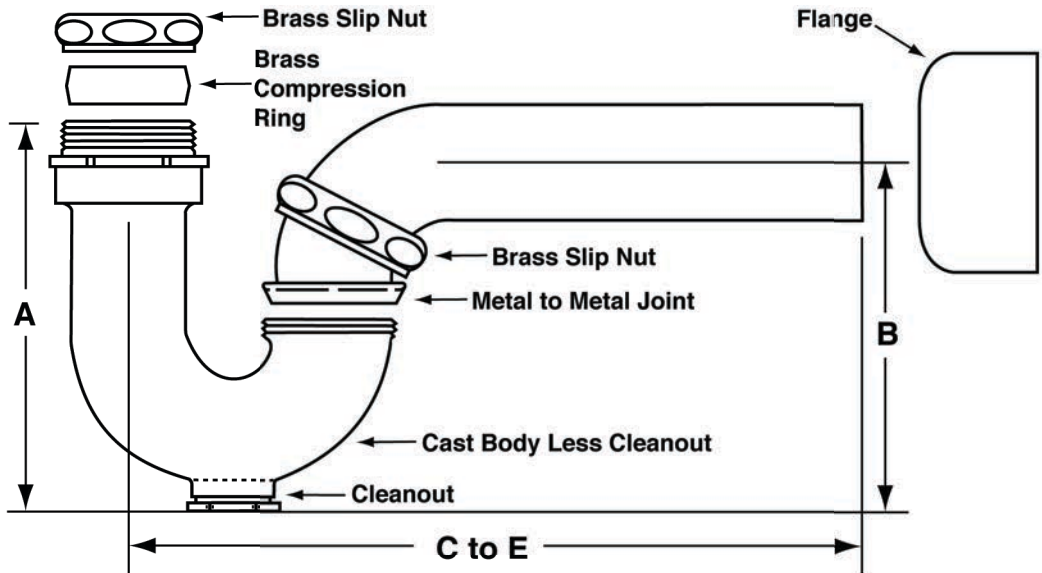

ROUGHING MEASUREMENTS

NO.	TRAP DIMENSIONS	A	B	C to E
V8902C	1-1/4" Inlet x 1-1/2" - 17 G.A.	6"	4-3/4"	12"
V8902CNC	1-1/4" Inlet x 1-1/2" - 17 G.A.	5-3/4"	4-1/2"	12"
V8912C	1-1/2" Inlet x 1-1/2" - 17 G.A.	6"	4-3/4"	12"
V8912CNC	1-1/2" Inlet x 1-1/2" - 17 G.A.	5-3/4"	4-1/2"	12"

**FED SPEC W.W.P. 541
 CAST BRASS P TRAP
 MINIMUM SEAL 2"**



See options and accessories section for details on product variations.

ASME A112.18.2/CSA B125.2

Specifications:

Cast brass chrome plated adjustable P-Trap, vandal resistant, with cleanout. Furnished with polished and chrome plated cast J-Bend without cleanout, chrome plated brass slip nuts, heavy brass vandal inlet and outlet connections. Trap shall be certified by CSA or other recognized testing authority. P-Trap shall bear manufacturer and testing mark.

WARNING:

This product can expose you to chemicals including lead, which is known to the State of California to cause cancer, and birth defects or other reproductive harm. For more information go to www.P65Warnings.ca.gov.



McGuire Manufacturing Co., Inc.

60 Grandview Court
 P.O. Box 746 • Cheshire, CT 06410
 203-699-1801 • Fax: 203-699-1813
 www.mcguiremfg.com

PRODUCT SPECIFICATION

Part No.

V8912CSAN, V8902CSAN,
 V8912CNCSAN, V8902CNCSAN

Vandal Resistant P-Trap
 With or Without Cleanout

Job Name:

Submittal Number:

SANIGUARD® Vandal Trap®

A registered trademark of
 Component Hardware Group, Inc.

SANIGUARD® product protection is designed to protect the product itself. It is not a disinfectant and does not protect users or others against food-borne illness or disease. Always use good hygiene and cleaning practices.

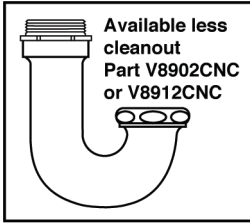
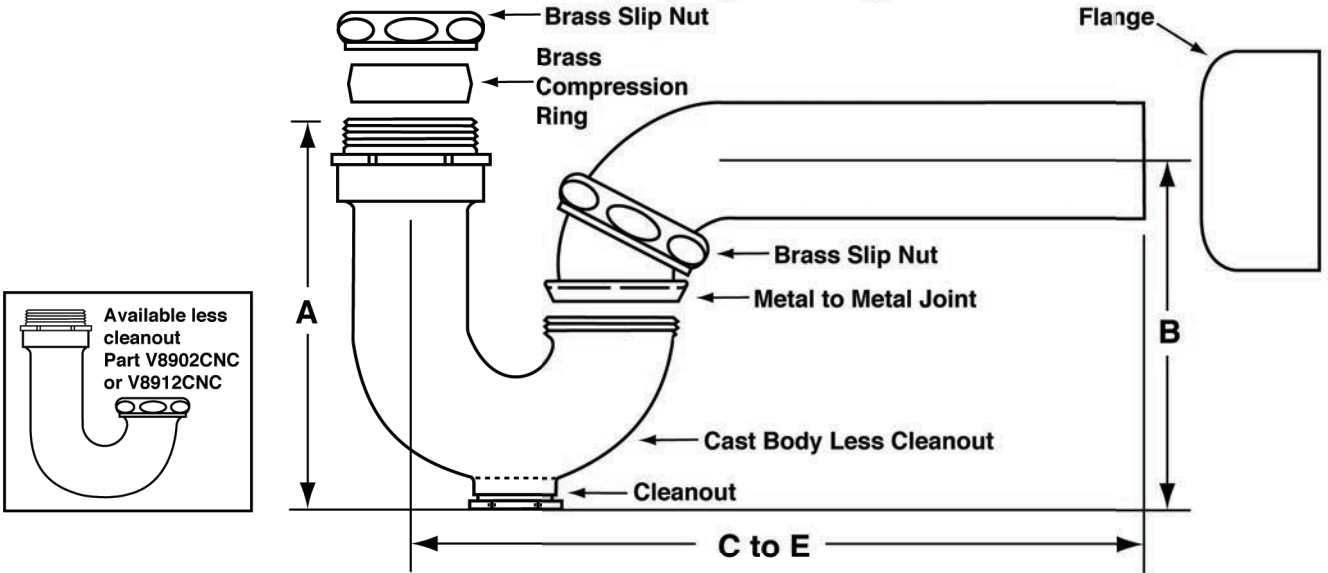

ROUGHING MEASUREMENTS				
NO.	TRAP DIMENSIONS	A	B	C to E
V8902CSAN	1-1/4" Inlet x 1-1/2" - 17 G.A.	6"	4-3/4"	12"
V8902CNCSAN	1-1/4" Inlet x 1-1/2" - 17 G.A.	5-3/4"	4-1/2"	12"
V8912CSAN	1-1/2" Inlet x 1-1/2" - 17 G.A.	6"	4-3/4"	12"
V8912CNCSAN	1-1/2" Inlet x 1-1/2" - 17 G.A.	5-3/4"	4-1/2"	12"

FED SPEC W.W.P. 541
CAST BRASS P TRAP
MINIMUM SEAL 2"



See options and accessories section for details on product variations.

ASME A112.18.1-2011/CSA B125.2-11

Specifications:

Cast brass chrome plated adjustable P-Trap, vandal resistant, with or without cleanout. Furnished with polished chrome plated cast J-Bend, chrome plated brass slip nuts, heavy brass vandal inlet and outlet connections. Trap shall be certified by CSA or other recognized testing authority. P-Trap shall bear manufacturer and testing mark. All metal parts shall be treated inside and out with SANIGUARD antimicrobial compound.

! WARNING:

This product can expose you to chemicals including lead, which is known to the State of California to cause cancer, and birth defects or other reproductive harm. For more information go to www.P65Warnings.ca.gov.