



**McGuire Manufacturing Co., Inc.**

60 Grandview Court  
P.O. Box 746 ♣Cheshire, CT 06410  
203-699-1801 ♣ Fax: 203-699-1813  
www.mcguiremfg.com

**PRODUCT SPECIFICATION**

**Part No.**

**151**

**Brass Basket Strainer**

**Job Name:**

**Submittal Number:**

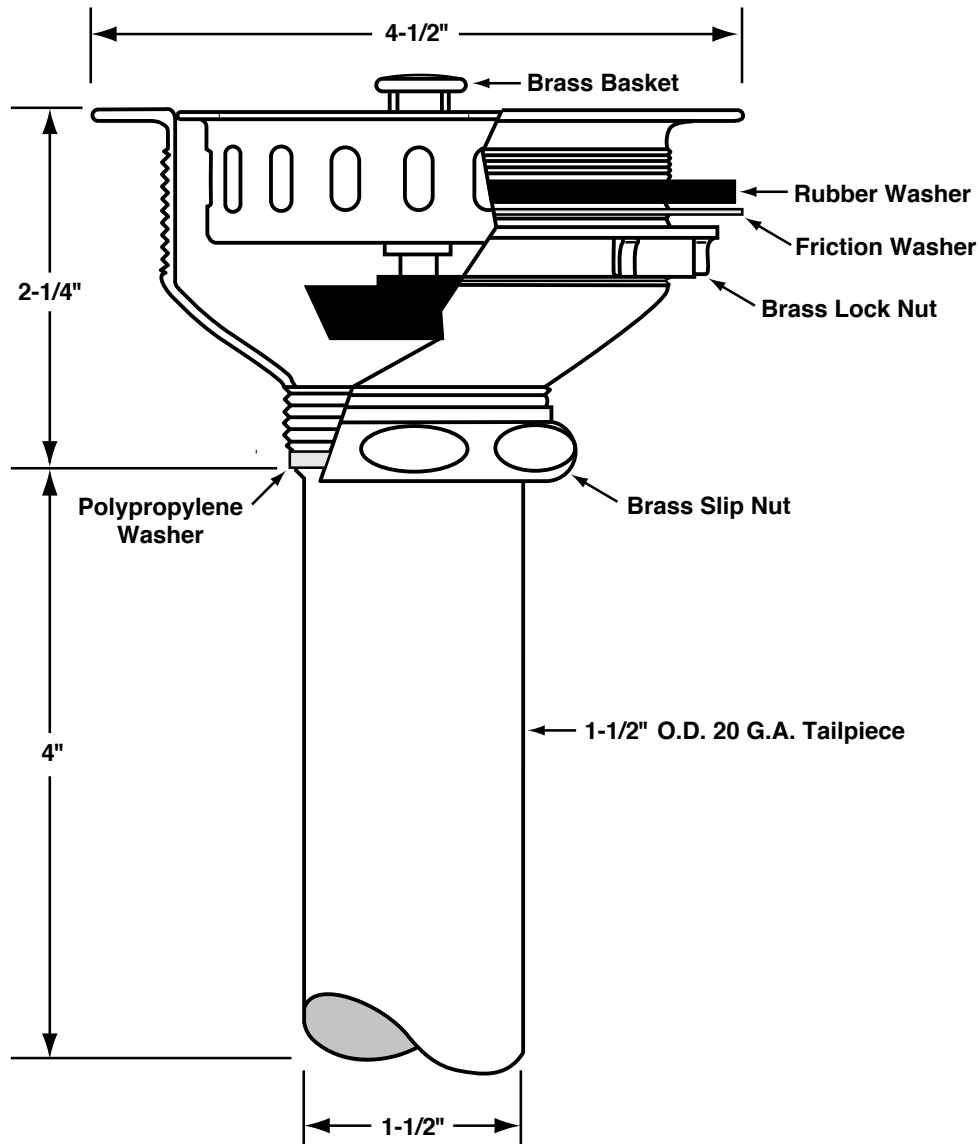

See options and accessories section for details on product variations.

**Specifications:**

Heavy Duty Forged Brass Basket Strainer with a polished and chrome plated brass strainer body, 1-1/2" x 4" seamless brass tailpiece, cast brass lock and coupling nuts. Fits sink thickness up to 3/4 inch. Basket Strainer shall be in compliance with CSA or other recognized testing authority and bear both manufacturer and testing mark.